



## Overview

The SGA01 is a two-channel user adjustable strain gauge amplifier. Each channel is DC isolated and designed for full-bridge operation, but can be adapted for use in half-bridge and quarter-bridge applications.

The output range of each channel is  $\pm 9\text{V}$  with input signal gain adjustable from approximately 25 to 1000.

Wire connection to the amplifier is via screw terminal contacts for simple fitting.

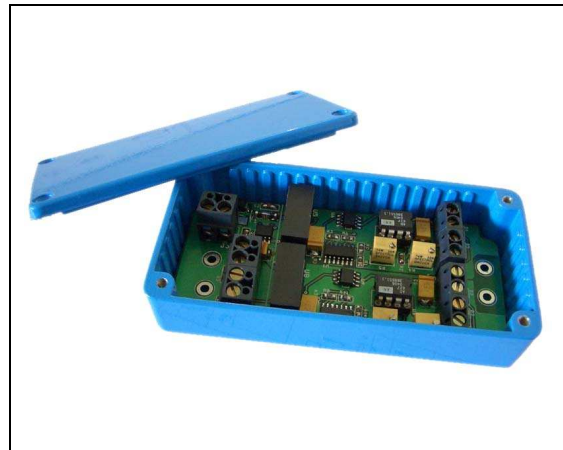

## Features

- Dual channel
- DC isolated channels
- 90dB typical CMRR
- Adjustable gain from 25 to 1000

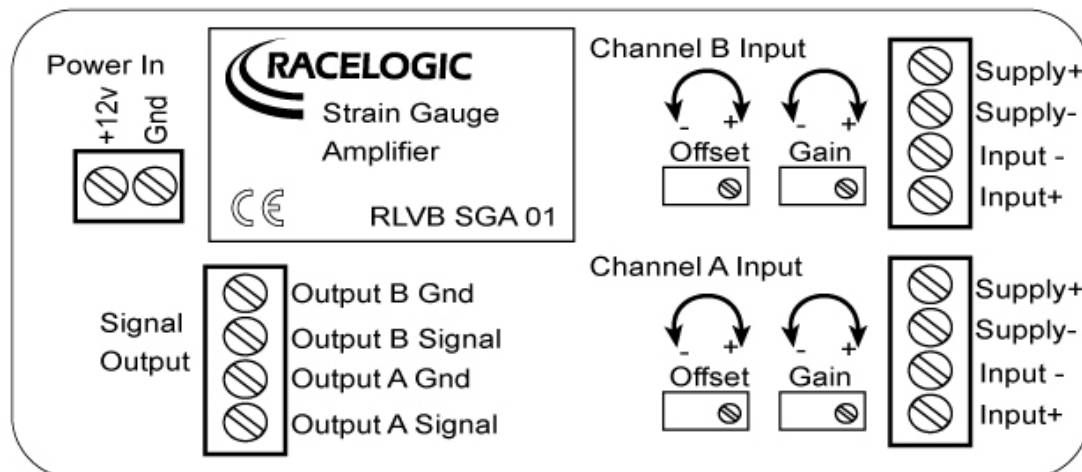

## Specification

Supply voltage	6v to 18vDC
CMRR	Typically 90 dB (min 77dB)
Bridge Supply Voltage	5v $\pm 2\text{mV}$
Gain	Adjustable from 25 to 1000
Output range	$\pm 9\text{V}$
Operating temperature	-40 to +85 °C



## Typical application

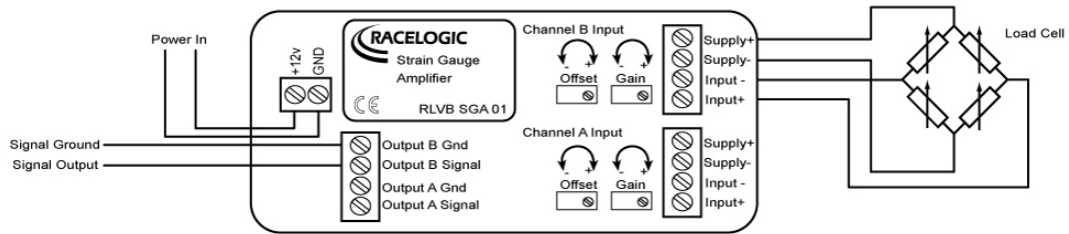

The Strain Gauge Amplifier can also be used in half-bridge and quarter-bridge applications. Please refer to the user manual for more information.

## External dimensions

